

Grid Tracking Inverter Concept for Grid Synchronization and MPPT with Solar Power Production System for Distributed Power System

Meera Murali

B.TECH, MG University, Kottayam.

M.E., Anna University, Chennai.

Assistant Professor, College of Engineering, Karunagapally

Thara Murali

B.TECH scholar, Sree Buddha College of Engineering

University of Kerala, Tiruvananthapuram

Abstract- The paper presents a system that converts power generated from renewable resources to a source having same voltage and frequency with respect to traditional power plant. The major area where the proposal is focusing on is the GRID TRACKING INVERTER, which is used to track the grid voltage. The power produced by the renewable energy resources, for example, solar panel, is converted to constant direct current with the help of a closed loop buck-boost converter and stored in a battery. The constant direct current is then converted to 230V/50Hz in synchronization with traditional mega power grid supply with the help of grid tracking inverter. Since the power generated has the same voltage and frequency with respect to grid, this can be used for grid synchronization. Special MPPT techniques are used to extract the maximum power from solar panel to achieve maximum efficiency in operation. This project also aims to assess an incremental conductance method to extract maximum power. With incremental conductance method, the number of sensors required will be reduced and presents very good transient performances when subjected to rapid changes in the atmospheric conditions. With this proposal power capability of grid can be improved and also a highly reliable, low cost power system can be obtained.

Keywords- Energy conservation, PV applications, MPPT, Grid tracking inverter, Grid connected system.

I. INTRODUCTION

India is facing an acute energy scarcity which is hampering its industrial growth and economic progress. Setting up of new power plants is inevitably dependent on import of highly volatile fossil fuels. Thus, it is essential to tackle the energy crisis through judicious utilization of abundant renewable energy resources, such as biomass energy, solar energy, wind energy and geothermal energy. Apart from augmenting the energy supply, renewable resources will help India in mitigating climate change. India is heavily dependent on fossil fuels for its energy needs. Most of the power generation is carried out by coal and mineral oil-based power plants which contribute heavily to greenhouse gases emission.

Decentralized energy generation or Micro generation, also called “micro power”, is the generation of zero or low-carbon electrical power by individuals, small businesses, and communities to meet their own needs. The most widely used micro generation technologies include small wind turbines, solar power photovoltaic or biomass conversion systems that have been promoted for decades as alternative sources of renewable energy. Because of technological advances, micro generation now includes hand held solar and wind power recharging devices for personal electronics, as well as advanced photovoltaic, biomass and wind-turbine systems for domestic and industrial power generation.

The voltage and frequency generated from the renewable energy resources exhibits instability and fluctuates or ceases unexpectedly. For e.g. the solar power is available only in sunny bright day time and is not available at night. The power produced from the solar panels may be feeble in misty, rainy and winter seasons. Wind and tidal energies are stipulated to the weather and we cannot predict its presence, speed and direction. Also power from solar panels will be low voltage, direct current (DC) and cannot be applied to AC machines.

The objective of this proposal is to develop a system that can convert power generated from renewable energy resources to a supply having same voltage, frequency with respect to a traditional power plant. The project mainly focuses on the grid tracking inverter where DC-AC conversion takes place.

Despite all the advantages presented by the generation of energy through the use of PVs, the efficiency of energy conversion is currently low and the initial cost for its implementation is still considered high, and thus it becomes necessary to use techniques to extract the maximum power from these panels, to achieve maximum efficiency in operation. It should be noted that there is only one point of maximum power (MPP – Maximum Power Point), and this varies according to climatic condition. Extraction of maximum power is a complex task. This paper also aims to assess an improved incremental conductance method to extract maximum power.

This paper can be a solution for the problems and rising energy needs of Indian industries. The proposal is as follows.

- a. Convert the power produced by the renewable energy resources to constant direct current.
- b. Store this energy in a battery.
- c. Convert the power in the battery to 230V/50Hz in synchronization with traditional mega power grid's supply with the help of grid tracking inverters.

Since the power generated has the same voltage, frequency with respect to grid, this can be used for grid synchronization. A low cost grid tracking inverter can be developed with following details. If the system is implemented by each consumer, massive power can be uploaded to the grid in day time, the peak load time, thus we can reduce the consumption of fossil fuels, water and nuclear fuels. The consumer can buy electricity as well as sell it. Consumers need to pay if and only if his consumption is greater than production. Otherwise the power distribution agencies will credit his account for his excess production.

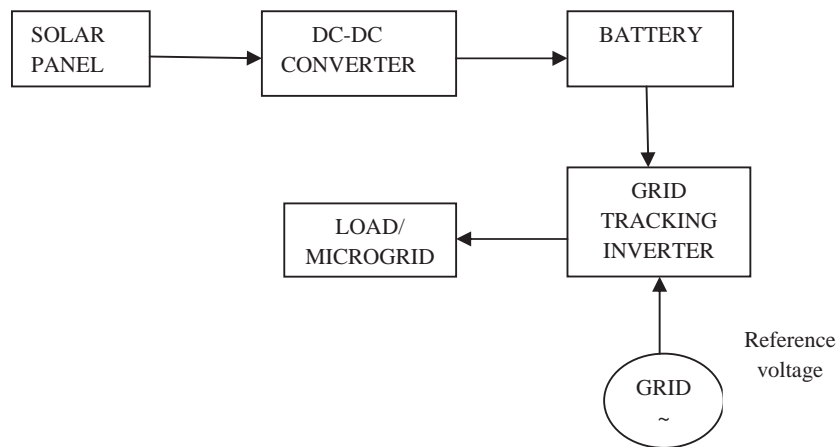

Fig.1 Basic block diagram of grid synchronization

A. Literature Survey-

Renewable resources produce a varying DC voltage with which grid synchronization is not practical. Considering the case of India, the grid voltage is 230V, 50Hz whereas, in some European countries, the grid voltage is 110V, 60Hz. In India, grid synchronization is possible only if the voltage from renewable resource is 230V, 50Hz. So for grid synchronization additional equipments must be provided along with the renewable resource in order to convert varying DC voltage to a voltage of 230V, 50Hz.

For obtaining a voltage of 230V, 50Hz it is necessary to incorporate additional equipments. A DC-DC converter and a DC-AC converter are the additional equipments used for this purpose. A DC-DC converter is used to convert variable DC voltage to constant DC voltage. A DC-AC converter is used to convert the constant DC voltage to a voltage of 230V, 50Hz.

Some of the drawbacks in existing systems are no closed loop control, voltage variation is transferred to output, one controller and housing have to be spending for each unit, large filters, increase of switching losses and high current ripples, complicated control of DC bus voltage, low cost and high efficiency are not achieved with these system, additional complex circuits and no power capability improvement.

B. Proposed System-

Even though there is many sources for electric power this paper focus on the solar power system. The idea of the paper is to fill up the power shortage in a domestic grid supply during day time due to increased power consumption. The proposed system will convert power generated from sunlight to 230V/50Hz.

However this is a knotty task to achieve this goal. Solar panel is one of the power generating units in our system. This section contains an array of photovoltaic cells that absorbs the energy in the photons and converts it into electric potential. The voltage from solar panels depends on weather and fluctuates in presence of clouds. Hence we have to regulate the voltage of the power generated from the solar panels. This regulated voltage can be stored in a battery for future production. Also battery will provide proper sourcing current.

For proper regulation of output voltage a closed loop buck-boost dc-dc converter must be used. Since conventional buck converters are able to buck upto half of the total voltage and conventional boost converters are able to boost up to twice the voltage, lack of reliability occurs so conventional buck-boost, buck or boost converters are not used for this proposal.

Over charging of battery will be controlled by dc-dc converter. Battery is the storage media of power. This battery can be either rechargeable batteries or super capacitors. E.g. lead acid, nickel cadmium, nickel metal hydride.

The next step is to invert the power stored in the battery to alternating current using power electronic circuits. During this process output voltage and frequency of the system in the same level as the grid's supply. Hence we have to monitor the values of both grid and output voltage and frequency.

This paper utilizes inverter topology to convert the direct current from the battery to alternating current of the same voltage and phase angle of the grid. This in turn requires high power solid state switches, typically MOSFETs or IGBTs. This proposal utilizes any of such power modules in our inverter section to switch the output transformer. The output transformer will be a step up transformer for obtaining proper output voltage. Zero crossing detectors will control the switching.

a. Solar Panel-

Solar panel absorbs the energy in the photons by an array of photo voltaic cells and converts it into electric potential. Solar cells are connected electrically and encapsulated as a module. Photovoltaic modules have a sheet of glass on the front side which allow light to pass while protecting the semiconductor wafers from abrasion and impact due to wind-driven debris, rain, hail etc. Solar cells are also usually connected in series in modules, creating an additive voltage. Connecting cells in parallel will yield a higher current [13][20].

The solar cell works in three steps.

1. Sunlight contains photons that hit the solar panel and are absorbed by semiconducting materials, such as silicon.
2. Electrons are knocked loose from their atoms which cause an electric potential difference. Current starts flowing through the material to cancel the potential and this electricity is captured. Due to the special arrangements of solar cells, the electrons are only allowed to move in a single direction.
3. An array of solar cells converts solar energy into a usable amount of direct current (DC) electricity.

b. DC-DC Converter-

The voltage from the solar panels depends on weather and fluctuates in presence of clouds. Hence the power generated from the solar panels must regulate. This can be done with the help of dc-dc converter. The dc-dc converter is used to convert variable power produced by renewable energy resources to constant direct current. And for reliable operation of the system this power must be stored in a battery. Proper care must be taken in order to prevent over charging and leakage of the battery to the solar panel in absence of light.

The DC-DC converter can be classified into:

1. Buck converter
2. Boost converter
3. Buck-boost converter
4. Cuk converter

Buck converter acts as step down chopper. It is used to step down the voltage. But there are certain limitations with conventional buck converter. If V is the voltage at the input side, it can step down the voltage only upto $V/2$. Boost converter acts as step up chopper. It is used to step up the voltage. Conventional boost converters have certain limitations. If V is the voltage at the input side, it can step up the voltage only upto $2V$. Buck-boost converter acts as both step up and step down chopper. It is used to step up as well as step down the voltage. Conventional buck-boost converters have certain limitations. If V is the voltage at the input side, it can step up the voltage only upto $2V$ or step down the voltage only upto $V/2$. The Cuk converter is similar to buck-boost converter. It provides an output voltage that is less than or greater than the input voltage, but the output voltage polarity is opposite to that of the input voltage.

All the above converters transform voltage, and not the current. So for achieving MPP, various MPPT techniques have been used. Fixed Duty Cycle, Constant Voltage, Perturb and Observe (P&O) and Modified P&O, Incremental Conductance (IC) and Modified IC, Ripple Correlation and System Oscillation methods are the various MPPT techniques [9][12][15]. Of these, P and O method is simple and much less complicated. Rest all methods are complicated and costlier when compared to P and O method. But the drawback of P and O method is that it can't track accurate MPP. So in order to overcome these drawbacks one method is use of high

frequency transformers. These transformers are able to transform both current and voltage. Thus power is transformed. Second method is use of a closed loop dc-dc converter with MPPT. In this paper the second method is adopted with a closed loop Boost converter.

Usually buck operations are not done. So buck converters are not used. With buck-boost converter and cuk converter 77-82% efficiency is obtained for MPPT. But with boost converter 85-90% is obtained for MPPT. It is because of this reason boost converter is preferred.

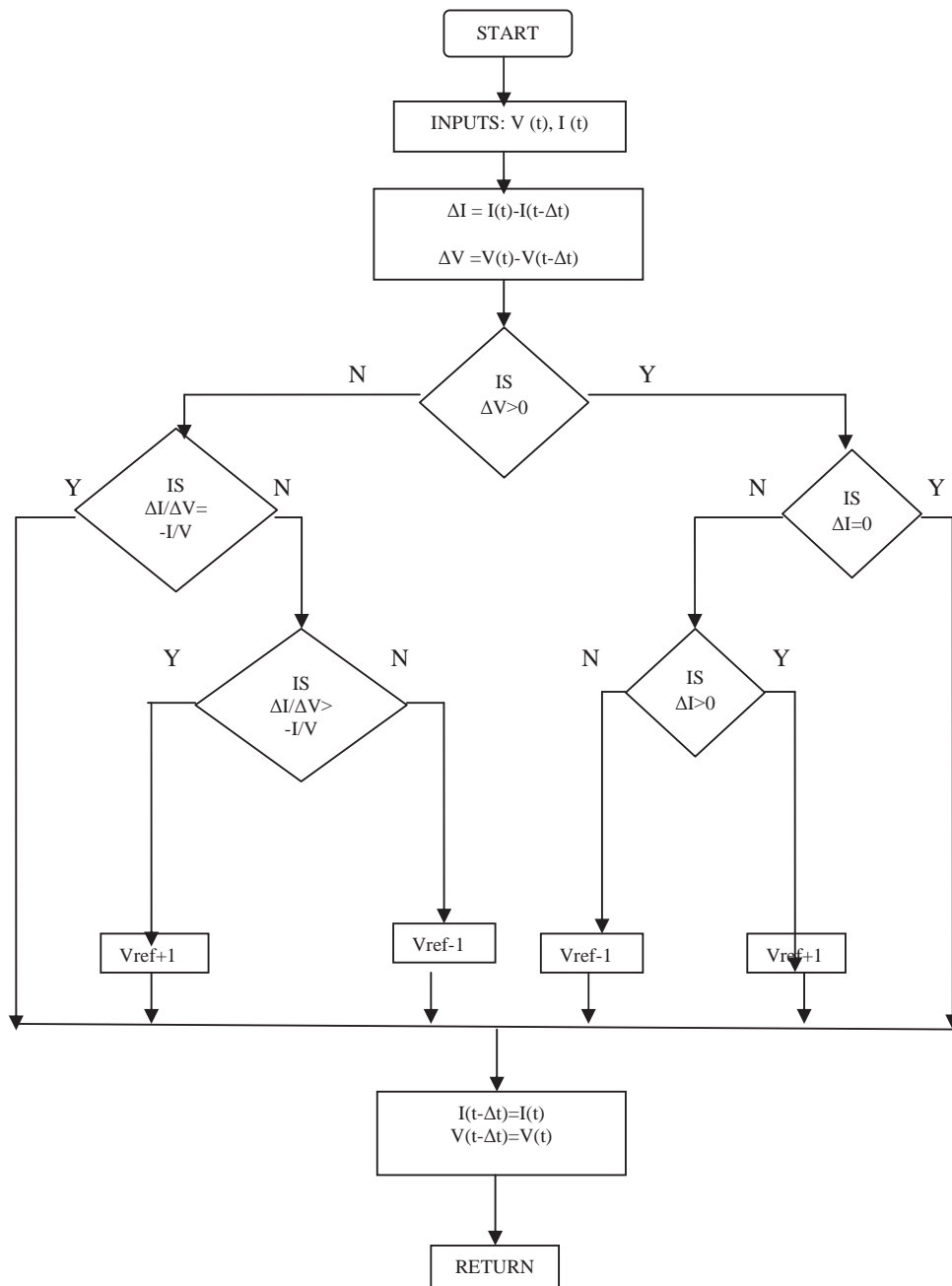

Fig.2 Flowchart for incremental conductance method.

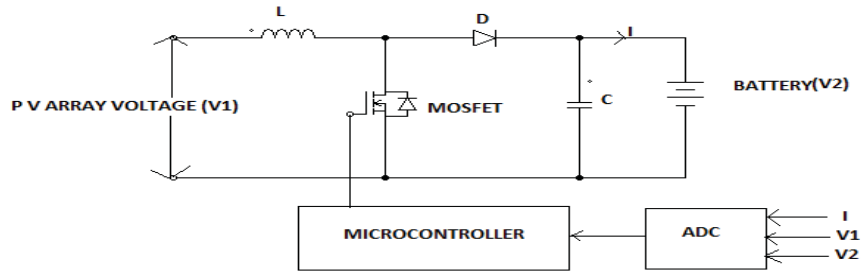

Fig.3 Closed loop boost converter

The basic principle of a Boost converter consists of 2 distinct states: In the On-state, the MOSFET is ON, which results an increase in the inductor current. In the Off-state, the MOSFET is OFF and the only path offered to inductor current is through the flyback diode D, the capacitor C and the battery. This result in transferring the energy accumulated during the On-state into the capacitor. The input current is the same as the inductor current. So it is not discontinuous as in the buck converter and the requirements on the input filter are relaxed compared to a buck converter.

c. Grid Tracking Inverter-

The grid voltage is step down to a low voltage and is given to a zero-crossing detector. The outputs from the zero crossing detectors are square wave. Now a positive half cycle and a negative half cycle is obtained.

The integrated power switching module and step up transformer together perform the function of push-pull inverter [5][7][16][11]. The two MOSFETs are alternately switched so that one of the primary coil of the transformer will conduct at a time. So the two MOSFETs need driver circuit. It is done with the help of transistor or on- off controllers. When transistor is ON or on- off controller is OFF, corresponding MOSFET is OFF. When transistor is OFF or on- off controller is ON, corresponding MOSFET is ON. The output of the grid tracking inverter is compared with the grid voltage.

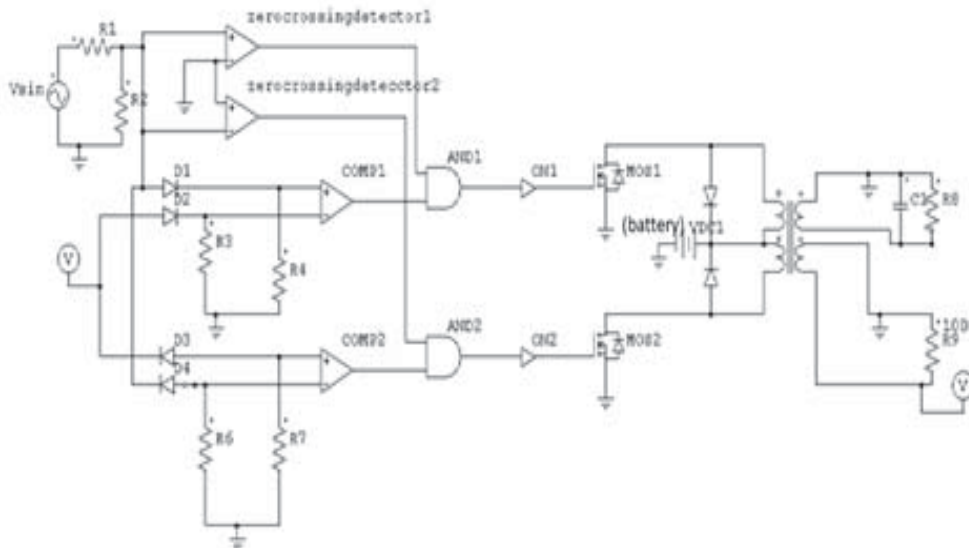

Fig.4 Circuit diagram for grid tracking inverter.

Grid voltage > inverter voltage and positive half cycle determines switching of MOSFET 1.
 Grid voltage < inverter voltage and negative half cycle determines switching of MOSFET 2. Thus coil 1 and coil 2 of transformer primary will conduct. Resulting tracked positive and negative half cycle.

III EXPERIMENT AND RESULT

A. Simulation Software and Simulation results-

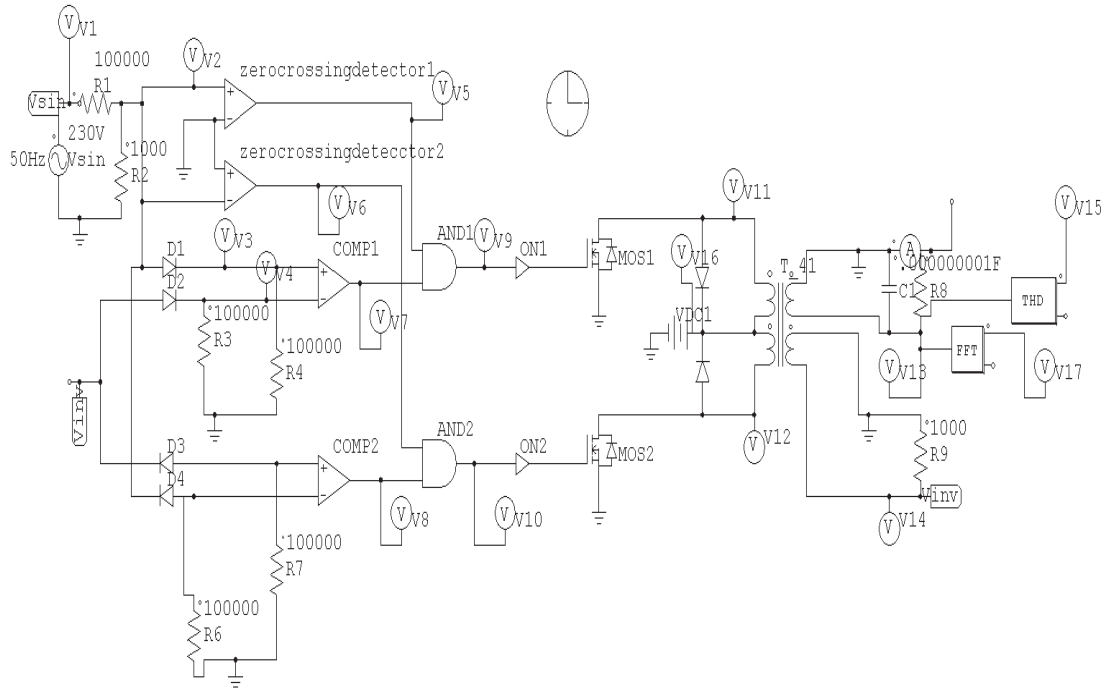

Fig.5 Simulation circuit diagram for grid tracking inverter in PSIM

PSIM is simulation software designed for power electronics, motor control, and dynamic system simulation. PSIM covers circuit level and system level simulation [7][13]. PSIM uses a strong algorithm dedicated to electrical circuits (piecewise method, generic models and a fixed time- step). As a result, simulation times are significantly reduced, convergence problems avoided while results accuracy is saved, one can rapidly get reliable results conformed to own expectations and requirements. With fast simulation and friendly user interface, PSIM provides a power simulation environment to address the simulation needs. The output voltage from the inverter and the grid voltage are equal in magnitude (Fig.7) and have same frequency. So this can be used for grid synchronization. The switching frequencies of MOSFET's are high. This frequency depends on slew rate of operational amplifier. The total harmonic distortion (THD) is less than 1.8 % (Fig.10). With FFT analysis came to conclusion that second harmonics are eliminated.

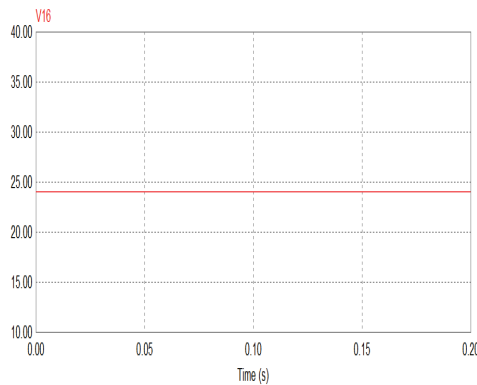

Fig.6 Battery voltage 24Vdc

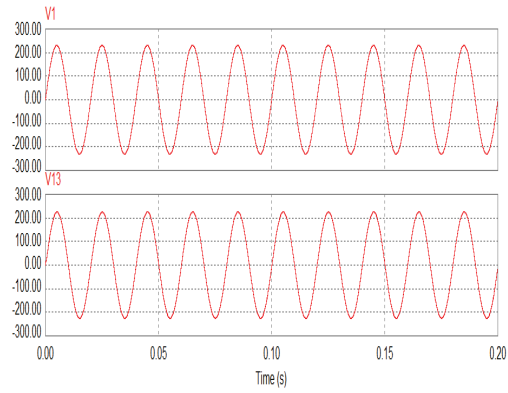

Fig.7 Grid voltage and inverter voltage 230V, 50Hz

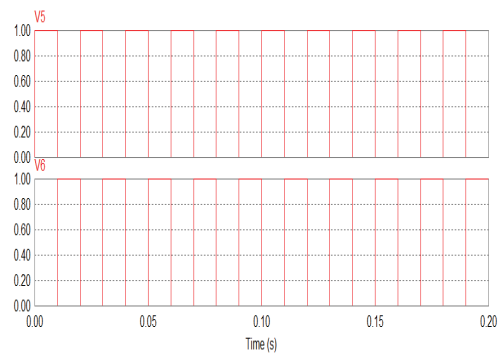

Fig.8 Output voltage from zero crossing detector 1 and zero crossing detector 2

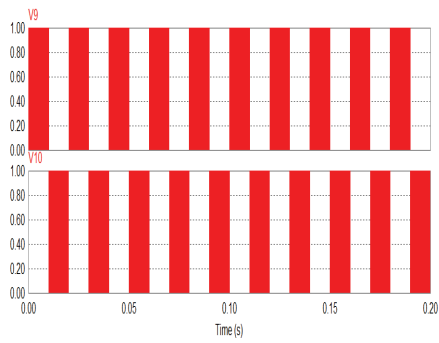

Fig.9 Switching pulses for MOSFET 1 and MOSFET 2

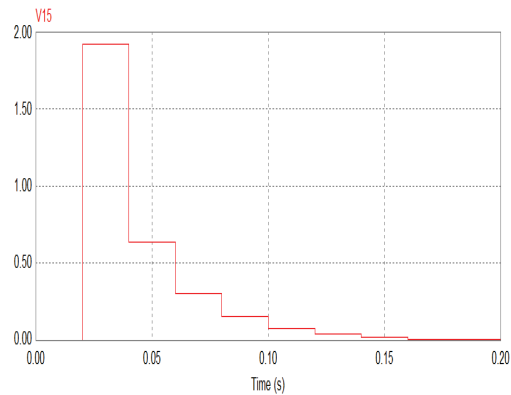

Fig.10 THD analysis

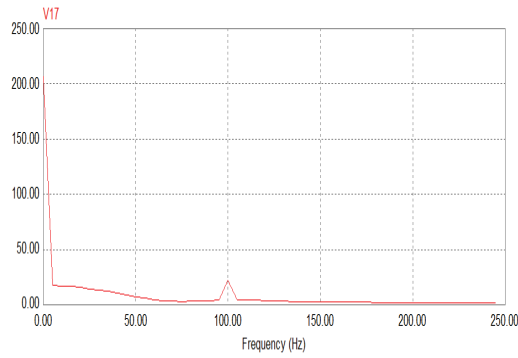

Fig.11 FFT analysis

B.

Hardware results

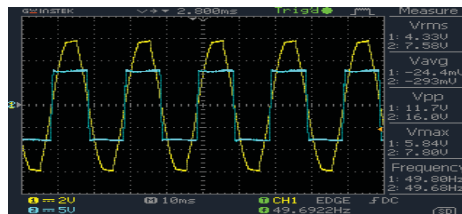

Fig.12 Waveforms of grid voltage and zero crossing detector

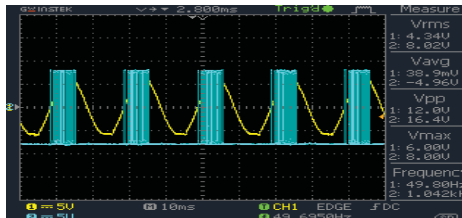

Fig.13 Waveforms of grid voltage and switching pulses of MOSFET 1

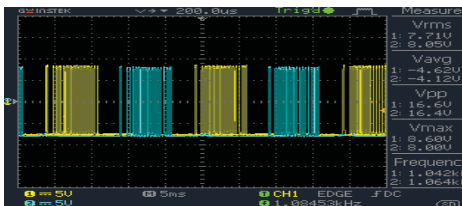

Fig.14 Switching pulses of MOSFETs

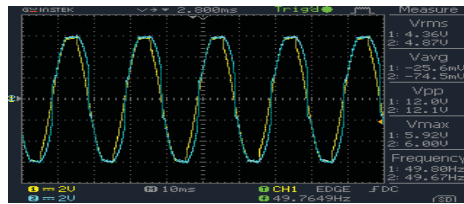

Fig.15 Waveforms for grid voltage and inverter voltage for inductive load

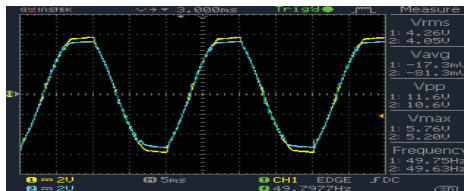

Fig. 16 Waveforms for Grid voltage and inverter voltage at overload condition with resistive load

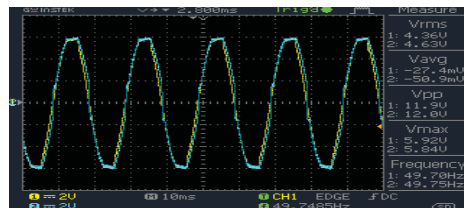

Fig.17 Waveforms for grid voltage and inverter voltage for capacitive load

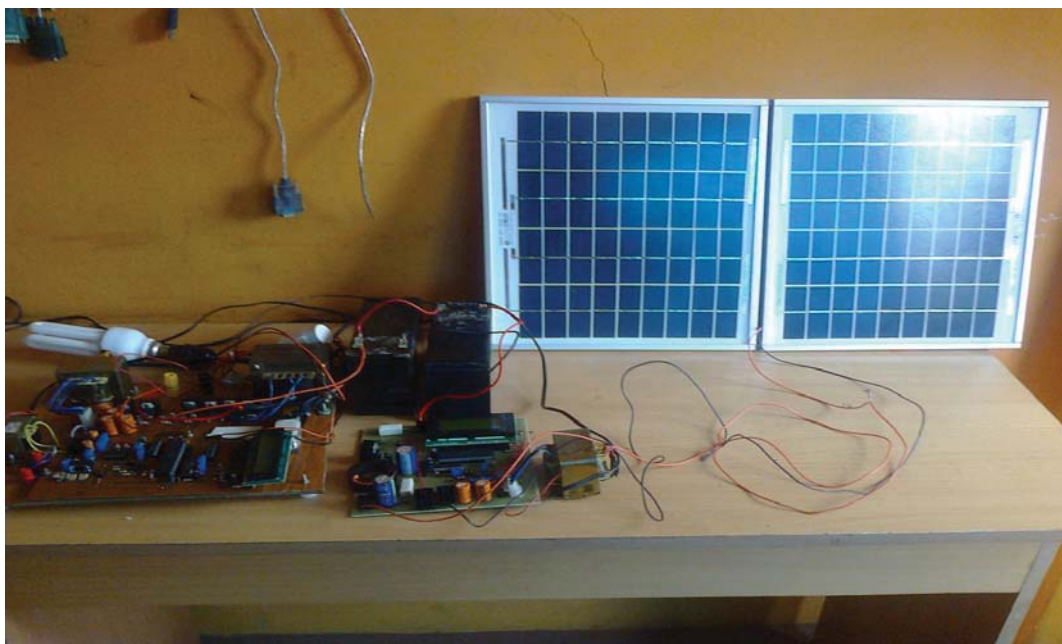

Fig.18 Hardware for the proposed system

IV. CONCLUSION

With this proposal a low cost grid tracking inverter is developed for grid synchronization which can reduce the overall cost of renewable power system and also the power capability of the grid can be improved. If the proposed system is implemented by each consumer massive power can be uploaded to the grid in day time, the

peak load time, thus we can reduce the consumption of fossil fuels, water and nuclear fuels. The paper is concluded by highlighting the key features and advantages.

This is the only solution up to date because of the following reasons. Solar energy is renewable and is available almost 6 hours every day. It is free. It is green energy, non-polluting and eco friendly. No byproducts or waste during operation. Cheap and can be implemented by every electricity consumers. Maximum energy production at peak load time. We can save our planet by saving fossil fuels and water during day time. The consumer can buy electricity as well as sell it. Consumer need to pay if and only if his consumption is greater than production. Otherwise the power distribution agencies will credit his account for his excess production.

REFERENCES

- [1] A. Lohner, A. Nagel, and T. Meyer, "A new panel integratable inverter concept for grid connected photovoltaic systems", in *Proc. IEEE Int. Symp. Ind. Electron.*, 1996, pp.827-831.
- [2] Chung, H. S.; Tse, K. K.; Hui, S. Y. R.; Mok, C. M.; Ho, M. T.: A novel maximum power point tracking technique for solar panels using a SEPIC or Cuk Converter. *IEEE Transactions on Power Electronics*, v. 18, n. 3, pp. 717-724, 2003.
- [3] G. Grandi and D. Ostojic, "Dual inverter based MPPT algorithm for grid connected photo voltaic systems," 978-1-4244-0/08 2009 IEEE.
- [4] G. C. Hsieh, S.W. Chen, and C.Y.Tsai,"Interleaved Smart Burp PV Charger for Lead Acid Batteries with Incremental Conductance MPPT," in *proc.IEEE ECCE phoenix*,pp.3248-3255,2011.
- [5] Ho, B.M.T., and Chung, H.S.-H.: 'An integrated inverter with maximum power tracking for grid-connected PV systems', *IEEE Trans. Power Electron.*, 2005, 20, (4), pp. 953-962.
- [6] Hsieh, G. C.; Chen, H. L.; Chen, Y.; Tsai, C. M; Shyu, S. S.: Variable Frequency Controlled Incremental Conductance Derived MPPT Photovoltaic Stand-Along DC Bus System. Proc. of 23rd IEEE APEC, 2008, pp. 1849-1854.
- [7] Koizumi, H.; Mizuno, T.; Kaito, T.; Noda, Y.; Goshima, N.; Kawasaki, M.; Nagasaka, K.; Kurokawa, K.: A novel microcontroller for Grid-Connected Photovoltaic Systems. *IEEE Transactions on Industrial Electronics*, v. 53, n. 6, pp. 1889-1897, 2006.
- [8] Liu, S. Duan, F. Liu, B. Liu and Y. Kang, "A V ariable Step Size INC MPPT Method for PV Systems," *IEEE Trans.Ind.Electron.*,vol.55, No.7,pp. 2622-2628,2008.
- [9] Moacyr A. G. de Brito, Leonardo P. Sampaio, Luigi G. Jr., Guilherme A. e Melo, Carlos A. Canesin"Comparative Analysis of MPPT Techniques for PV Applications," 978-1-4244-8930-5/11/\$26.00 ©2011 IEEE
- [10] N. A. Rahim and J. Selvaraj, "Multilevel inverter with dual reference modulation technique for grid connected PV system," 978-1-4244-4241-6/09 2009 IEEE
- [11] Roberto Gonzalez, Jesus Lopez, Pablo Sanchis, Eugenio Gubia, Alfredo Ursua and Luis Marroyo, "High efficiency transformerless single phase photovoltaic inverter" 1-4244-0121-0/06 2006 IEEE.
- [12] S. Jain and V. Agarwal," Comparison of the performance of maximum power point tracking schemes applied to single-stage grid-connected photovoltaic systems" *IET Electr. Power Appl.*, 2007, 1, (5), pp. 753-762.
- [13] Sameer Khader, Alan Hadad and Akram A. Abu-aisheh (2011) The Application of PSIM & Matlab/ Simulink in Power Electronics courses. 2011 IEEE Global Engineering Education Conference (EDUCON), JORDAN.
- [14] Saeed Azimi, Behzad Mirzaeian dehkordi, Mehdi Niroomand,' An Adaptive Incremental Conductance MPPT Based on BELBIC Controller in Photovoltaic Systems" 978-1-4673- 1 148-91 12/\$31.00 ©2012 IEEE.
- [15] Shuai, Dong Cao, Yuan Li and Fang Zheng Peng, "Grid connected boost half bridge photovoltaic microinverter system using repetitive current control and maximum power point tracking," *IEEE Trans. Power Electron.*, vol.27. no.11.november 2012.
- [16] Soeren Baekhoej K jaer, Frede Blaabjerg,"Design Optimization of a Single Phase Inverter for Photovoltaic Applications,"0-7803-7754-0/03/\$17.00© 2003 IEEE.
- [17] Yaow Ming Chen and Kuo Yuan Lo, "Multi-string single-stage grid connected inverter for PV system," 978-1-4577-0541-0/11 2011 IEEE.
- [18] Young Hyok Ji, Doo Yong, Jun Gu Kim, Jae Hyung Kim, Tae Won Lee and Chung Yuen Won, "A real MPPT for mismatching compensation in PV array under partially shaded conditions," *IEEE Trans. Power Electron.* vol.26. no.4. april 2011.
- [19] books.google.com/books/Electronics_Devices_And_Circuits.html
- [20] http://solar.gwu.edu/Reserch/Energy_Policy_zweibel2010